

## EE 361L, Laboratory 3 Traffic Light Controller

Design a controller for the traffic light on Dole Street near the Parking Structure (in the Quarry) using the PIC16F84A. That traffic light controls automobile traffic on Dole Street and pedestrian traffic crossing the street. The outputs of the controller are Red (R), Yellow (Y), Green (G), Don't-Walk (D), and Walk (W). There are two inputs, B1 and B2, which are each connected to a Pedestrian-Walk button. The outputs and inputs correspond to the pins of the 16F84A as follows  $R = RB0$ ,  $Y = RB1$ ,  $G = RB2$ ,  $D = RB3$ ,  $W = RB4$ ,  $B1 = RA0$ , and  $B2 = RA1$ .

There are four states of the traffic light as shown in Figure 1:

- **R/W1**: Traffic light is Red and pedestrian light is Walk. The controller is in this state for 3 seconds.
- **R/W2**: Traffic light is Red and pedestrian light is a blinking Walk. The Walk is blinking to caution pedestrian that it will soon turn to Don't Walk. The Walk goes on 1/2 sec, off 1/2 sec, on 1/2 sec and so on. The controller is in this state for 3 seconds.
- **G/D**: Traffic light is Green and pedestrian light is Don't Walk. The controller is in this state for at least 6 seconds. The controller will get out of this state when
  - 6 seconds have elapsed *and*
  - one of the pedestrian buttons has been pushed (goes on) since the end of the last R/W1 state, i.e., the beginning of the last R/W2 state.
- **Y/D**: Traffic light is Yellow and pedestrian light is Don't Walk. The controller is in this state for 3 seconds.

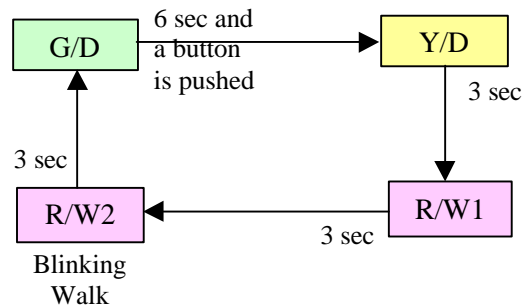

**Figure 1. Transitions of traffic light controller.**

To check if a pedestrian button were pressed, the controller samples RA0 and RA1 approximately every 1 ms to check if they are on.

Hint: To facilitate debugging, have an additional output which indicates when a pedestrian button (B1 and B2) has been pressed. Use an LED to indicate when this output is on.