

University of Hawaii

EE 260 Introduction to Digital Design

Building LogicWorks Device Modules

Here are the steps to build a LogicWorks circuit module. The first step is to design a LogicWorks circuit. Then draw a graphical symbol to represent it. Then "bind" the parts of the drawing to the inputs and outputs of the circuit.

Step 1. Create a LogicWorks circuit

Example:

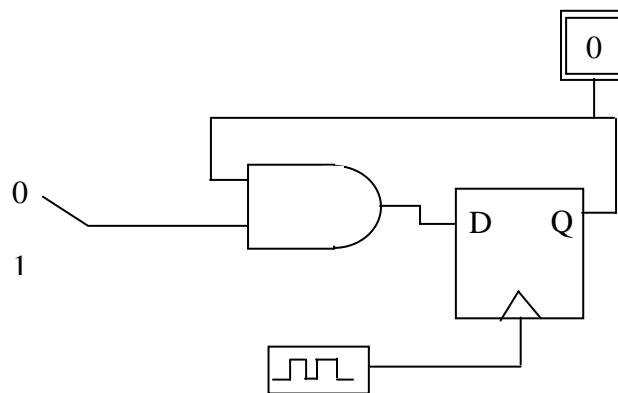

Make sure that the circuit works before proceeding to make a module of it.

Step 2. Create a "Subcircuit"

A **subcircuit** is basically a circuit (as created in Step 1) but without any simulation IO elements like the probes or switches, and no clock generator elements. This will leave the inputs and outputs of the circuits disconnected. Now attach **port connectors** to the inputs and outputs (including clock inputs). See the figure below for an example subcircuit. Port connectors are pseudo devices, and can be found in the `pseudo.clf` and `connectors.clf` libraries. Port connectors that are connected to inputs are "Port In", and port connectors that are connected to outputs are "Port Out". In the example below, **InDev** and **Clk** are input ports, while **OutDev** is an output port.

By attaching the port connectors, the LogicWorks program now know that these will be attached to the input and output pins of your circuit module.

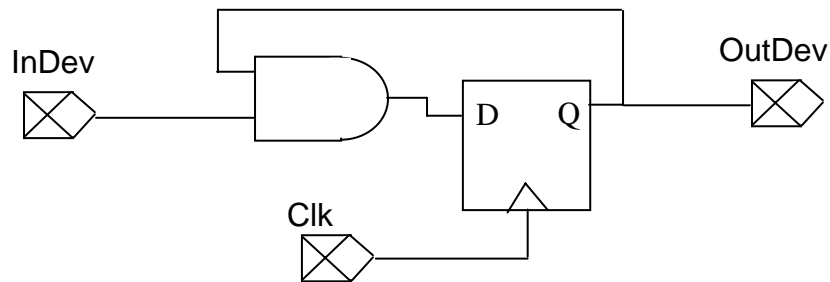

The port connectors should be given names. To assign a name to a port, point and click with the right mouse button the port. A menu will pop out and you can select a name. In the example, the ports were given the names InDev, Clk, and OutDev in this way.

Keep the window of the subcircuit open.

Save the circuit and remember it's name, since you'll need it in Step 3.

(There's some information about subcircuits in LogicWorks 5 manual on page 53, but not a whole lot.)

Step 3. Load Your Device Library

This is where you keep all the devices you create. If you don't already have one then create a new one. Recall that to edit your device library you can open up the library maintenance menu by pointing the mouse to the parts palette and right click the mouse.

Step 4. Create a Device Symbol

From the **File** menu, select **New**, which will open another menu. Then select **Device Symbol**. This will open a window to create a new device.

Select the **Options** menu, and then "**Subcircuit/Parts Type**". This opens another window. Select "**Create a sub-circuit symbol and select an open circuit to attach to it.**" Click the subcircuit that you have opened in Step 2. Then you are done with this part.

Now note that on the left side is the pin list. It should show the names of all the ports of your subcircuit. For our example, we should have InDev, Clk, and OutDev.

Draw a symbol for your device. This will typically be a block diagram that consists of a single rectangle and some **pins**.

Notice that at the top of the LogicWorks frame, there's various graphical shapes you can choose for the symbol, e.g., rectangles, ovals, text, and "T"s in various positions: right side up, upside down, on its left side, and on its right side. Draw the rectangle first. Next place the pins, which are the "T"s. Note that there are different types of Ts: thin, thick, and ones with bubbles in the middle. Use the thin Ts.

Note that each pin should correspond to a name in the pin list. To place a T (or pin):

- Single click the corresponding port connector in the Pin List, e.g., InDev. This should highlight the name in the list.
- Single click the appropriate pin and place it in your drawing. To place the pin, move it to where you want to place it and click it there. Note that the pin corresponds to the base of the T, so the top of the T should be flush with the side of the module.

Note that in the pin list, there is a window for a Pin Number. The pin number for a pin is the text that appears by the pin in the device symbol. By clicking a pin, the window will have the corresponding pin number. The default number is "blank". For the pin number, you can enter a number or text. Enter the pin numbers of the pins of your device.

You should also put a name on your module by typing text on it.

The following shows an example device symbol. In this case, InD, C, and OutD are the pin numbers of InDev, Clk, and OutDev, respectively.

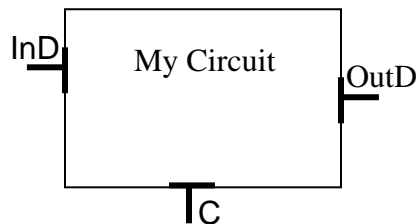

Step 5. Save the Symbol to the Library

Save to your library. Do this by going to the **File** menu and saving. Note that at this point, you can give the part a name. Choose your library to save it to. Then close the window.